

ULF-246 & SSPF-20 REPAIR PARTS

REF. NO.	PART NO.	DESCRIPTION	NO. REQ.
1	830662	Main Frame Weldment (ULF-246)	1
2	831156	Main Frame Weldment (SSPF-20)	1
3	830671	Fork Shaft Weldment	1
4	830674	Fork Tine Weldment	2
5	830678	Fork Adjustment Collar	4
6	2503191	Set Screw $\frac{3}{8}$ " - 16 NC x $\frac{3}{4}$ " Square Hd.	4
7	2503004	Bolt $\frac{1}{2}$ " - 13 NC x $1\frac{1}{2}$ " Hex Hd.	1
8	2501003	Washer $\frac{1}{2}$ " Flat	1
9	2502002	Washer $\frac{1}{2}$ " Springlock	1
10	2500003	Nut $\frac{1}{2}$ " - 13 NC Full Hex	1
11	830679	Parking Stand (ULF-246)	2
12	2503055	Bolt $\frac{3}{8}$ " - 16 NC x 1" Carriage Head (ULF-246)	2
13	2502008	Washer $\frac{3}{8}$ " Springlock (ULF-246)	2

REF. NO.	PART NO.	DESCRIPTION	NO. REQ.
14	2500004	Nut $\frac{3}{8}$ " - 16 NC Full Hex (ULF-246)	2
15	830317	Lift Bracket (ULF-246)	2
16	940009	U-Bolt $\frac{5}{8}$ " - 11 NC x 3" ID x 4" Lg. (ULF-246)	4
17	2502007	Washer $\frac{5}{8}$ " Springlock (ULF-246)	8
18	2500013	Nut $\frac{5}{8}$ " - 11 NC Full Hex (ULF-246)	8
19	830309	Lift Pin 1" Dia. x 8" Lg. (ULF-246)	4
20	590034	Linchpin $\frac{1}{4}$ " (AK-61) (ULF-246)	8
21	101026	Decal - Caution (Read Instruction Manual)	1
22	101034	Decal - Caution (Heavy Load)	1
23	101037	Decal - Caution (Observe Rated Capacity)	2
24	101098	Decal - Caution (Never Exceed Lift Capacity)	1
25	101099	Decal - Parking Stand (ULF-246)	2

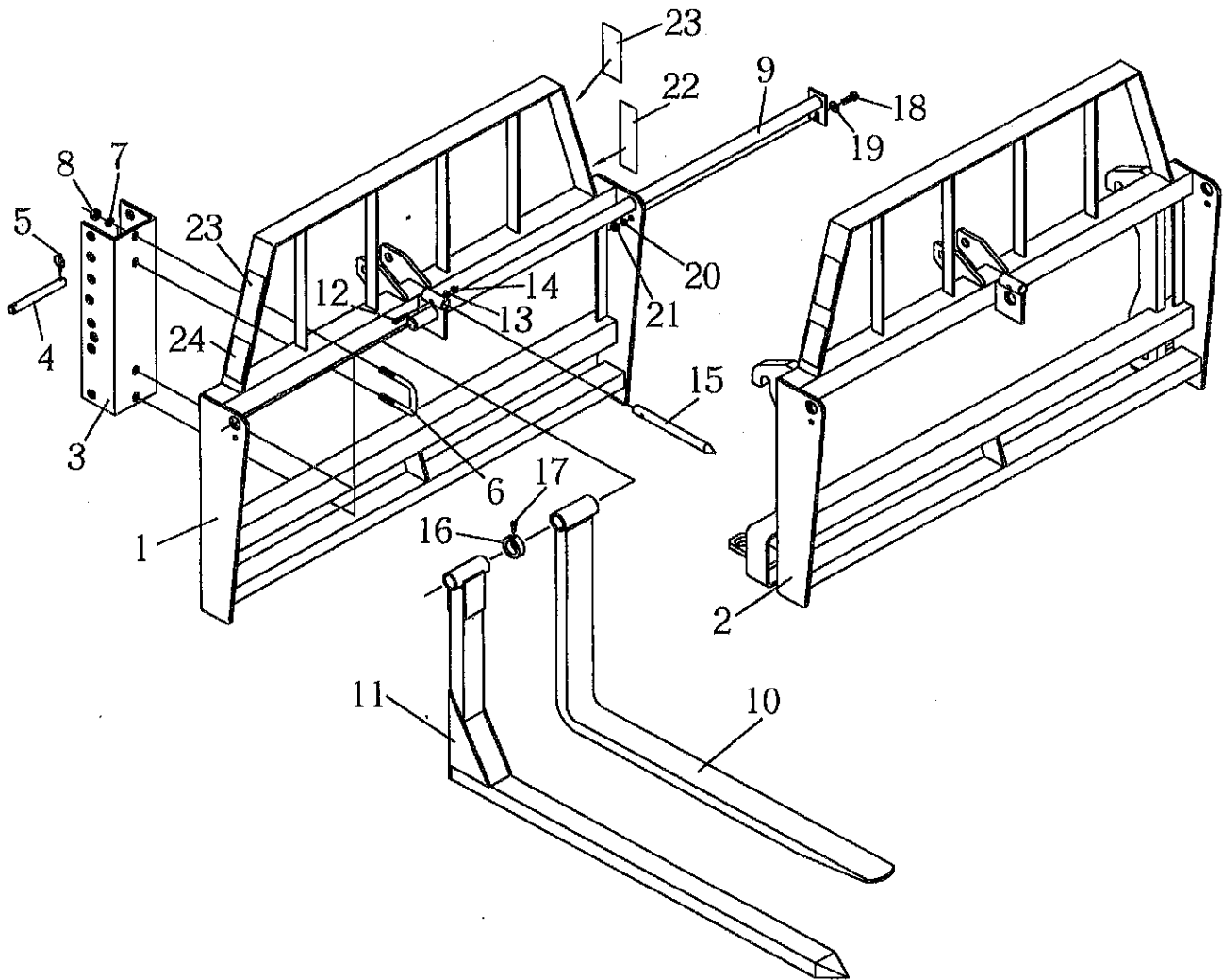

ULF-346, ULF-355, VLF-7646, & VLF-7655 PARTS LIST

REF. NO.	PART NO.	DESCRIPTION	NO. REQ.
1	830522	Main Frame Weldment (ULF-346 & ULF-355)	1
2	830564	Main Frame Weldment (VLF-7646 & VLF-7655)	1
3	830317	Lift Channel (ULF-346 & ULF-355)	2
4	830309	Lift Pin ($\phi 1"$ x 8" Lg.)(ULF-346 & ULF-355)	4
5	590034	Linch Pin 1/4" (AK-61)(ULF-346 & ULF-355)	8
6	830214	U-Bolt 5/8"-11NC 3" x 4 1/2" (ULF-346 & ULF-355)	4
7	2502007	Washer 5/8" Springlock (ULF-346 & ULF-355)	8
8	2500013	Nut 5/8"-11NC Full Hex (ULF-346 & ULF-355)	8
9	830543	Fork Shaft Weldment	1
10	830546	Solid Fork Weldment (ULF-346 & VLF-7646)	2
11	830532	Tubular Fork Weldment (ULF-355 & VLF-7655)	2
12	2503111	Bolt 5/16"-18NC x 1 3/4" Hex Head	1
13	2502011	Washer 5/16" Springlock	1
14	2500011	Nut 5/16"-18NC Full Hex	1
15	830213	Balance Spike	1
16	830554	Fork Adjustment Collar	4
17	2503191	Set Screw 3/8"-16NC x 3/4" Square Head	4
18	2503004	Bolt 1/2"-13NC x 1 1/2" Hex Head	1
19	2501003	Washer 1/2" Flat	1
20	2502002	Washer 1/2" Springlock	1
21	2500003	Nut 1/2"-13NC Full Hex	1
22	101026	Safety Sign-Caution (Instruction Manual)	1
23	101037	Safety Sign-Caution (Observe Rated Capacity)	2
24	101097	Safety Sign-Caution (Never Exceed Lift Capacity)	1